

deli

User Manual

AIR COMPRESSOR

DL-WKY25-E1

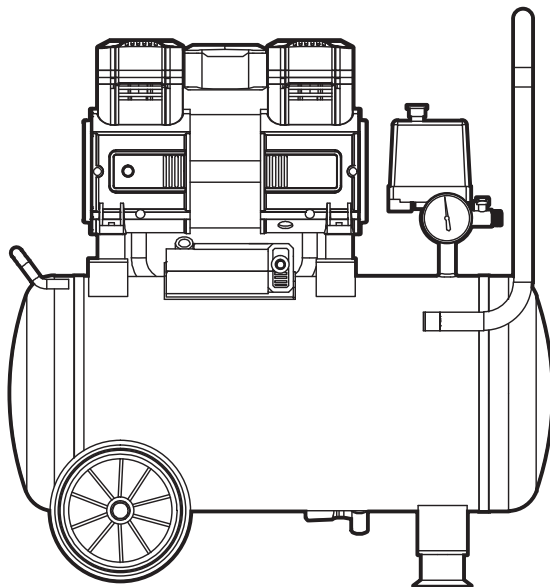

Contents

I. After-sales Service Introduction	2
II. Product Introduction	2
III. Main Technical Parameters	3
IV. Air Compressor Instructions	3
V. Usage Requirements	3
VI. Maintenance	4
VII. Troubleshooting Form	4

I. After-sales Service Introduction

1.1 Preface

First of all, thank you for choosing our oil-free air compressor meticulously designed based on the world's leading-edge technology, and main parts are made of imported materials. All corporate products have undergone strict inspection and testing before leaving the factory, but to ensure safe and reliable running of air compressor and guarantee a long service life, please make sure you spend some time reading this instruction manual in details before use, for the sake of correct use and maintenance. If you still have any doubt, please do not hesitate to contact the company or your nearest dealer, and we will offer you satisfactory service. Hopefully, our products will facilitate your work and life.

1.2 Service content

1.2.1 Quality assurance

During the warranty period, if corporate product parts are defective or damaged, the company will replace them free of charge or in a paid manner. Corporate Technology Department is the sole agency authorized to confirm whether damage falls within the warranty scope. This warranty excludes direct or indirect personal or physical loss or damage caused by incorrect operation and repair of the machine, limited to damage of materials and components(excluding normal wear and tear of all parts).

1.3 Receipt

1.3.1 When you receive air compressor, please first check whether it conforms to the model and specification you have ordered.

1.3.2 Whether the machine and accessories have been damaged during transportation. In case of shortage or damage, please contact corporate business personnel who will solve it for you successfully!

II. Product Introduction

Our oil-free air compressor (hereinafter referred to as air compressor) is widely applied in dentistry, farming, food, medicine, fitness, beauty, chemical engineering, scientific experiment and more domains, thanks to the offering of pure and eco-friendly air source without oil pollution, and it may also serve as vacuum pump. Its major advantages are as follows:

2.1.1 The motor is equipped with a new two-level advanced design system, with newly optimized structural design, ensuring the compressor to achieve low input power, low energy consumption, high performance and high reliability.

2.1.2 Piston ring is designed with new eco-friendly material, small friction coefficient and self-lubrication, replacing the oil lubrication history of traditional piston machines. Furthermore, it will not produce any hazardous substance containing oil, without secondary pollution to the air source.

2.1.3 Cylinder liner adopts advanced surface hardening treatment process, which considerably reduces thickness and accelerates heat transfer; effectively enhances surface density and wear resistance, and decreases friction coefficient, thereby extending service life and reducing overhaul time and cost.

2.1.4 Intake and exhaust valve sheets are made of Swedish valve steel belts after more than 100 hours of precision rolling treatment, plus rational mute design, greatly raising volume efficiency, and the noise is significantly lower than other similar products.

2.1.5 Multi-pressure and overload protection ensure smooth and reliable running of the machine.

2.1.6 The whole machine boasts considerate design, flexible movement, simple operation and convenient preservation.

2.1.7 The whole machine leverages new external protection device design.

III. Main Technical Parameters

Model Name	Displacement	Work Pressure	Input Power	Rotating speed	Volume	Noise	Net weight	Power Cord Diameter	Overall Dimension
	L/min	(BAR)	(KW)	(RPM)	(L)	(dBA)	(KG)	mm2	L × W × H(mm)
DL-WKY25-E1	80	7.0	1.2	2800	25	70	19	1	580 × 265 × 540

IV. Air Compressor Instructions

4.1) Put switch button in ON or Auto position (there is operation diagram on the pressure switch shell), turn on the power, and the machine starts. If the machine cannot start, please reduce air pressure in air tank below 0.4MPa to start it.

4.2) Put switch button in OFF position (press down red cap of pressure switch), cut off the power, and the machine stops running.

4.3) The switch comes with a safety valve. When the pressure in air tank exceeds 0.88MPa, safety valve will beep to release air and relieve pressure. In the event of safety valve beeping, please repair air pressure switch, and avoid working pressure of air pressure switch beyond the rated working pressure.

4.4) After stopping the machine every day, please gently resist the thimble below the oil-water separator with fingers to drain away sewage in the oil-water separator. (For some users who may not need an oil-water separator, such item does not apply during use, and neither does the function in Article 4.5 below).

4.5) The pressure of air released from exhaust valve can be adjusted by pressure adjusting knob on the oil-water separator. Turn the knob clockwise to increase released air pressure, reaching pressure in air tank to the maximum,

4.6) and counterclockwise to reduce released pressure, shutting down air source to the minimum. Caution! When turning to the limit position, do not turn it forcefully to prevent damage.

4.7) To adjust working pressure of air pressure switch, please remove the upper shell of air pressure switch, adjust rotating screw in the pressure switch, turn it clockwise to increase working pressure, and vice versa. Note to cut off the power before operation. (There is operation diagram on the pressure switch shell)

V. Usage Requirements

5.1) Read this instruction manual before use.

5.2) Store air compressor in a dry and ventilated room, and strictly avoid approaching easy-to-decay, perishable, flammable and chemical objects. The storage period shall not exceed two years since the date of leaving the factory. After the storage period, conduct inspection and preservation, as well as necessary test.

5.3) It is strictly forbidden to collide with this machine. Put it upright when using, and prevent from tilting and upside down when moving to avoid malfunction.

5.4) In order to ensure safety and extend service life, place the machine in a ventilated, clean and cool place, and try to avoid using it in an environment with high temperature, dirty air, lots of dust or oily fuel exhaust gas.

5.5) Before powering on, make sure the machine in an off state. Turn on the power and switch to run. The power supply voltage shall not be lower or higher than 10% of the rated working voltage.

5.6) Prevent air compressor from getting wet by water, and do not place it in a damp and cool place to avoid malfunction.

5.7) Please do not touch high-temperature components while running, such as cylinder cap, exhaust pipe and one-way valve, so as to prevent scalding.

VI. Maintenance

Before all the preservation work, cut off the power and exhaust air pressure; otherwise, it is very dangerous!

6.1) Please keep the machine clean, scrub and maintain the machine on a regular basis.

6.2) Drain away sewage in the air tank at least once a week. When draining sewage, the pressure in the air tank shall be lower than 0.1Mpa.

6.3) Frequently check whether safety valve is sensitive, safety valve can release air easily, and upon pressing the valve stem, it restores immediately.

6.4) After every 500 hours of use, please remove the filter element of air filter for cleaning or replacement, take out air valve and wash; replace leather cup after every 2000 hours of use.

6.5) Perform pressure test of the air tank once every two years, check inner and outer surfaces once a year, and scrap the air tank in case of severe rust, severe bumping or pressure test failure.

VII. Troubleshooting Form

Warning: Before any preservation or overhaul work, cut off the power and exhaust air pressure in the air tank; otherwise, it will easily cause injury!

Fault Phenomena	Possible Causes	Disp
The motor cannot turn without any sound	1 No power 2 Disconnected pressure switch 3 Fuse blown 4 Overload protector in protective state 5 Damaged pressure switch 6 Burnt motor stator winding	1 Check plug and switch 2 Reset switch and investigate reason 3 Replace fuse 4 After the motor cools down, it will restart, and manually press the external protector button 5 Contact a reliable service center 6 Replace stator
The motor has a current sound but cannot run or at a very slow speed	1 Ultra-low voltage 2 Short circuit or open circuit of motor coil 3 Damaged one-way valve or air pressure switch	1 Check voltage, not less than 10% of the rated voltage 2 Contact a reliable service center 3 Contact a reliable service center
Overload protector repeatedly cuts off the power	1 Too low voltage 2 Bad ventilation, too high temperature 3 Motor fan blade installed in an opposite direction	1 Check voltage, not less than 10% of the rated voltage 2 Put air compressor in a well-ventilated place 3 Check fan blade for correct direction of installation
The pressure declines upon turning off air compressor	1 Loose connection of air circuit with leakage 2 Open drain valve 3 One-way valve leakage	1 Check each connector and eliminate air leakage of connector 2 Tighten drain valve 3 Assemble after dismantling and cleaning, and replace in case of problems
The released air contains plenty of water	1 Plenty of water in the air tank 2 Too high humidity	1 Drain away water in the air tank 2 Move air compressor to a place with low temperature, or use an oil water separator
Air compressor keeps running	1 Damaged air pressure switch 2 Leakage	1 Replace air pressure switch 2 Check and eliminate
Air compressor vibrates	1 Loose fastener 2 Damaged or missing bearing pad 3 Aging or damaged accessories in air compressor	1 Check and eliminate 2 Replace pad 3 Replace aging or damaged accessories
The pressure cannot increase or reach the specified pressure	1 Open drain valve 2 Clogged air filter 3 Air leakage 4 Malfunctioning valve sheet or with foreign objects or air leakage 5 Excessive wear of piston ring	1 Tighten drain valve 2 Clean or replace filter element 3 Check and eliminate 4 Wash or replace 5 Replace new product

Maintenance and precaution (this air compressor is prohibited from adding any grease)

- Before all the preservation work, cut off the power and exhaust air pressure; otherwise, it is very dangerous!
- Place air compressor in a dry and ventilated place!
- Power supply voltage shall not be lower or higher than 10% of the rated working voltage during use!
- Please do not touch high temperature components while running to prevent scalding.

Maintenance cycle and method (see instruction manual for details)

1. Drain water of air compressor tank at least once a week.
2. When draining sewage, the pressure in the air tank shall be lower than 0.1Mpa.
3. Blow the appearance of air compressor once a month, and keep air compressor as clean as possible.
4. After every 500 hours of use, please remove filter element of air filter for washing or replacement.
5. After around every 2000 hours of use, replace the piston leather cup.
6. Check the inner and outer surfaces of air tank once a year, prohibit from using it in circumstances such as severe rust and bumping, and scrap it.